

Asymmetrical Spinnaker 101 (also known as Flasher or Gennaker).

Equipment needed:

2 sheets each approximately twice the length of the boat light weight
1 tack downhaul line about the length of boat, if it is to be adjustable from the cockpit
3 Blocks : 2 for the sheet leads and 1 as the turning block for the downhaul
1 Halyard either the spinnaker or genoa halyard
ATN Tacker <http://www.atninc.com/atn-tacker-sailing-equipment.shtml>
or Parrel Beads required to roll over furling headsail.
<http://www.neilprydesails.com/store/beads.htm>
Spinnaker

Optional but recommended:

Dousing sock
Boom bail to have an attachment point on anchor roller if needed.

Size and fabric:

Measuring for a Spinnaker is very easy. The only dimensions needed are the I and the J measurements. Hoist a tape measure to the top of the mast with the Spinnaker halyard. If you do not have a dedicated Spinnaker halyard use your Jib halyard. Remember to tie a line to the halyard in case your tape breaks. Measure down to the top of the working deck, not the cabin top. This is your I dimension. Lower the tape measure. Now measure from where the forestay connects at the bow, back to the base of the mast. This is your J dimension.

For cruising spinnakers the luff can be plus or minus 8% of "I" but cannot exceed maximum hoist on the halyard. Spinnaker foot should fall between 1.6 and 1.8 X "J"

Good old nylon is still considered the "right stuff" for nearly all spinnakers. It's slightly stronger than polyester (Dacron), a bit less expensive, and its greater elasticity is, in some respects, an asset because it helps absorb shock loads. A good guide for wind strengths for different materials that will keep the sails out of the dangerous overloading range is below. Note that these are apparent wind speeds, not true wind speeds. Also, these apparent wind speeds should be lowered if the sail is old or has been overloaded in the past.

- .5oz cloth up to 10 knots AWS
- .75oz cloth up to 14 knots AWS
- 1.5oz cloth up to 18 knots AWS
- 2.2 oz cloth up to 21 knots AWS

A cruising spinnaker's best angles generated by varying apparent-wind direction and strength

Apparent-wind strength	Apparent-wind direction
5 knots	55-155 degrees
10 knots	60-155 degrees
15 knots	85-155 degrees
20 knots	120-155 degrees

For a first time user a used spi seems a wise choice, you just won't be as upset if you rip it ;)

Here are a few places where to find some.

<http://www.usedsails.com/>
<http://www.secondwindsails.com/>
http://www.pineapplesails.com/usedsail/web_spin.htm
<http://www.baconsails.com/sailsearch>



ATN Tacker

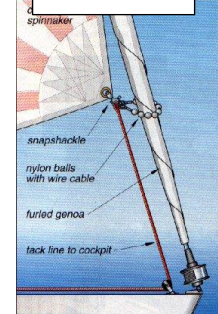

Parrel Beads

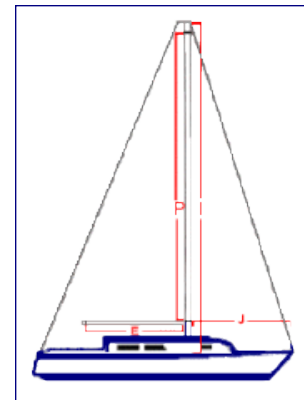

Setting up your Asymmetrical Spinnaker

(also known as Flasher or Gennaker).

While the cruising spinnaker is designed to enhance a boat's downwind performance, it also makes downwind sailing safe and easy, especially when sailing shorthanded. Because the tack of an asymmetrical remains attached to the forestay regardless of which tack the boat is on, the cruising spinnaker does not need a pole. Gybing a cruising spinnaker, much like gybing a genoa, is an easily controlled maneuver. Setting up an AS is basic. There are three attachment points for the AS and only two get adjusted while sailing.

Downhaul Line:

Lead the downhaul line through a block attached to the stem-head and back to the bow cleat. Many AS owners are attaching the downhaul line to the bow anchor roller if they have one. This is very effective because the bow roller is a few inches outside of the pulpit and keeps the sail free from the pulpit. Before attaching the tack to the anchor roller, make sure that the roller is reinforced enough to take the load of the downhaul line.

Sheets:

Attach the spinnaker sheets to the clew of the AS and lead them through a block on the port and starboard quarter and back to your cockpit winches. You can rig only one sheet if you are sure that you will not be jibing. If you are using two sheets, lead the lazy (windward) sheet around the headstay and back to the cockpit so that the AS will jibe outside of the headstay not through the fore triangle.

Halyard:

Attach the spinnaker halyard to the head of the AS or the top of the sock, whichever is applicable. Hoist the halyard to the top. You do not need to adjust halyard tension while sailing.

Hoist:

After you have attached the downhaul line to the bow, run a sheet to the stern and attached the halyard, turn your boat down wind so that the sail will be in the shadow of the mainsail and hoist. When the sail is fully hoisted, trim the sail and head up to course.

Sailing with your AS:

The sheet is the major control for your AS. You want to trim the sheet much like a symmetrical spinnaker. As the luff on the AS folds in, trim the sheet. If the luff of the AS never begins to fold in, then you probably need to ease the sheet. As you sail with your AS you will learn how much trimming is necessary.

Besides the sheet, you may want to adjust the downhaul line to optimize sail shape. When tight reaching, the AS will be more efficient with the downhaul line tight. When broad reaching, the downhaul line should be eased to allow the luff of the AS to project out in front of the boat.

Close Reaching:

In less than 5 knots of breeze, the AS provides a sail which fills in very light air with an apparent wind as close as 45 degrees. On reaches, the tack is pulled to the bow with the downhaul line. This makes the sail look and perform more like a genoa. In heavier air, the AS is set the same and powers up the boat.

Reaching:

Reaching from 85 to 45 degrees, the downhaul line can be eased to make the AS fuller and more powerful. In this configuration the AS performs more like a spinnaker.

Running:

Running, the downhaul line is eased even farther, and the sheet is eased more. This allows the AS to lift and perform like a powerful spinnaker. For dead down wind conditions, the AS can be flown wing on wing without a pole.

Easy to take down:

To take the AS down, sail down wind so the AS is in the backwind of the mainsail. Gather the AS from the tack and bring it to the deck. If it is light, you can pack it right into the bag; if it is heavy, just get it on the deck and pack it later.

Using a Dousing Sock:

The purpose of the sock is to keep the spinnaker confined during both hoisting and lowering. It is a good idea to use a dousing sock if your boat is over 30 feet long. When you hoist the spinnaker, it will be inside the sock and will not fill until you are ready for it to do so. Once you are ready to set the spinnaker, raise the sock to the top of the spinnaker by pulling the sock-control line.

When it is time to drop the spinnaker, bear away onto a square run so the spinnaker collapses behind the mainsail. Pull the sock-control line so the sock comes down over the collapsed spinnaker. Ease the spinnaker or genoa halyard so the sock and spinnaker are on the deck.

Jibing your AS:

There are two ways to jibe your AS.

With a Sock:

Before you jibe, douse the AS. With the sail safely in the [sock](#), take the [sock](#) and walk it around the forestay. You can bring the sail around the forestay before or after the actual jibe. If you are only using one spinnaker sheet, you will have to re-lead the sheet for the new jibe. Once you are set up on your new jibe, check to ensure that the sail is properly set up and pull up the [sock](#). This method takes more time than jibing without a [sock](#), but it is the safest. There is very little chance that you will rip your AS when using this method.

Without a Sock:

This method can be used if you have a sock and want to jibe quickly. This jibing method requires that both sheets be rigged to the asymmetrical. Rig the lazy sheet in front of the forestay and in front of the luff of the AS. It takes practice to perfect this method so you should be sure to try it slowly for the first few jibes. As you head down wind, ease the sheet of the AS all the way out. The sail will flow out in front of the boat. When the boat is directly down wind (it might help to have the main at centerline) begin to take in the new sheet.

The clew of the AS should pass in front of the luff of the AS. As you bring in the sheet steer through the jibe and begin sailing on your new jibe.

Note: Be sure that you do not have any sharp objects attaching the sheets to the sail. These could rip the sail during a jibe.

Maintenance:

Caring for your AS is easy but very important. In the unlikely event that your AS gets wet, be sure to dry the sail before storing it for long periods, if stored wet, the colors can sometimes run. Drying will also prevent mildew. You should have your AS cleaned every one to three years, depending on usage.